

Bond Mill Elementary

October 13, 2009

Dear Parents/Guardians,

This year at Bond Mill all fifth graders will be participating in the Prince George's County Public Schools' Write-A-Book Competition.

The fifth grade teachers appreciate your support. All stories and illustrations must be the original work of your child. Please allow your budding author the opportunity to unlock that special creative arena of the mind. Attached you will find a timeline of due dates, guidelines, checklists, and book binding information. If you have any questions or need more information, please contact your child's homeroom teacher.

Please begin to be on the lookout for thick cardboard pieces, as they are needed for the binding process. Also, any volunteers are welcome. Below is a form that needs to be returned to your child's homeroom teacher by **Friday, October 19, 2009**. Thanks in advance for all of your help and support!

The Fifth Grade Team

Justin FitzGerald, Principal

_____ I am aware that my child _____ is required to do the Write-A-Book project.

Parent's Signature

_____ I can help with Write-A-Book during the dates **November 12-20, 2009**.

(Name)

(Phone #)

Date(s)

Time(s)

1 October 2009

Dear K-5 Parents and Guardians,

This year Bond Mill is participating in the Prince George's County Public School's Write-a-Book competition. Bond Mill requires that all 4th and 5th graders write a book. Students in Kindergarten through 3rd grade may write a book if they would like to enter the competition. It is highly encouraged for 3rd grade students to participate, as it will be helpful practice for the coming year. Any student may submit a book.

This competition is an excellent opportunity for students to use skills they have learned and their creative talents in writing and illustrating. As students use elements of plot, characters and events to develop their stories, the skills needed for functional reading and writing are developed and reinforced. Participating in Write-a-Book compliments their school curriculum.

Students write to inform, persuade and express personal ideas and with continued practice they will continue to improve. During the writing and editing stages, students will practice many higher level-thinking skills and it will help them to improve in expressing their thoughts. Through the Write-a-Book competition, students can become more proficient readers and writers thereby broadening their scope of knowledge and development.

At Bond Mill we appreciate any support that you can provide. All stories and illustrations must be the original work of your child. Please do not trace drawings or allow anyone to illustrate the pictures in your student's book. Photographs are only allowed in the non-fiction category and the student author must take the photos. Therefore, your child's own photograph should not be featured in the text of the book. A photo of the student may appear in the "About the Author" section at the end of the book. Clip art and computer downloads are not acceptable under any circumstances. An adult may type the student's book to assist as long as the student has written, or dictated, the text and content of the book. It is also appropriate and highly encouraged to discuss the story with your child and help him or her by asking questions about the story, for example, "What does the character look like?" Use your questions to draw out information that is important for story that the student wishes to convey. This will help them to develop their story and to express their thoughts in writing. Please allow and encourage your budding author the opportunity to unlock that special creative area of his or her mind.

All books are due to your student's classroom teacher by Thursday, December 3rd, 2009.

This year we have included a form that should be submitted with the book to assist in ensuring that your child's book is placed in the correct category. This is a local form and will not be forwarded to higher competition. Please fill out the form and place it inside (do not staple or tape) the book. Thank you for your assistance.

Part of the further amendments that were provided last year is as follows. Please read and follow these and all requirements and rules. Please make sure that students understand that if they wish to have his or her book entered in the competition must strictly adhere to the competition requirements.

- If the text is typed, the font must be no smaller than 12 and no larger than 14. There is an exception; the font may be larger than 14 in the Picture Story Book and Poetry Categories for Heading and titles only.
- Books must be edited with appropriate grammar, spelling and punctuation. There can be no profanity, sexually explicit situations or excessive violence.

Feel free to contact us if you have any questions about the project. Our contact information is provided below. In the coming weeks we will hold an information session and at least two book binding nights. Thank you for your support and lets make this a great year for Write-a-Book.

Sincerely yours,

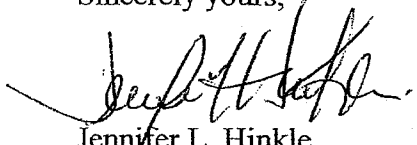

Jennifer L. Hinkle
Write-a-Book Chairperson
jen.hinkle@techtotems.com
(Home) 240-786-6038

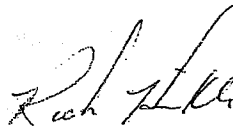

Rich Hinkle
Write-a-Book Chairperson
richard.hinkle@yahoo.com
(Cell) 301-325-8350

Write-A-Book Timeline

Yes, it's that time of the year! Write-A-Book! As a fifth grade project, all students will be required to participate. Below is a list of due dates for various parts of the project. Each teacher will explain and teach about each part of the project and the students are to complete them as an in class/at home project. Some class time will be given to starting and conferencing about each of the parts. The various assignments are turned in to the homeroom teacher.

Date due:

What is due:

October 19, 2009

Parent Note

October 26, 2009

Pre-Write of book idea/Graphic Organizer

October 28, 2009

Story Board layout

November 9, 2009

Rough Draft of book

November 12-13 and
16-20, 2009

Time on the computers at school to type, edit, and print final draft of book (Volunteers needed)

November 24, 2009

Typed copy of book

November 25-29, 2009

No School-students should work on completing typing and binding their books.

December 3, 2009

**BOUND BOOK WITH
ILLUSTRATIONS DUE!
CONGRATULATIONS!**

Guidelines for Elementary Book Categories (Grades K – 5)

<p style="text-align: center;">Picture Story Book</p> <ul style="list-style-type: none"> ➤ Illustrations on each page ➤ Limited or no text on each page ➤ Minimum number of pages: 10 	<p style="text-align: center;">Illustrated Fiction</p> <ul style="list-style-type: none"> ➤ Text with limited illustrations ➤ Maximum number of illustrations: 5 ➤ Minimum number of pages: 15 (including illustrations)
<p style="text-align: center;">Poetry</p> <ul style="list-style-type: none"> ➤ Illustrations are optional ➤ Minimum number of pages: 10 (including illustrations) 	<p style="text-align: center;">Non-Fiction</p> <ul style="list-style-type: none"> ➤ Text with limited illustrations and/or photographs ➤ Minimum number of pages: 15 (including illustrations)

Minimum and maximum number of pages refers to the body of the book.

Entry Groups
Individual Group (2-5 students)
Class-produced, teacher-guided (Picture Story, Poetry, or Non-Fiction categories only)

For each of the categories listed, each school may submit four qualified individual, four qualified group, and four qualified class-produced books for each grade level.

Write-A-Book

Student Checklist: Illustrated Fiction

Student Name(s) _____

Title of Book _____

Question	✓
Are there five or fewer pictures?	
Are there at least 15 numbered pages, but not more than 30?	
Is the story original and does it have a well-defined plot or theme? (30 points)	
Is there a clear order to the ideas? (10 points)	
Are the characters well-developed? (10 points)	
Does the story have appropriate grammar, spelling, and punctuation? (10 points)	
Are the illustrations creative and original? (20 points)	
Do the pictures match the story? (10 points)	
Does the book look neat? (10 points)	
Does the book have a hard cover?	
Is the book no larger than 10" x 12" and no smaller than 5" x 8"?	
Are the title and the author's name on the outside cover of the book?	
Is there a title page inside the book?	
Was the book written during this school year?	
Were the story and illustrations my/our own work?	

Write-A-Book

Student Checklist: Non-Fiction

Student Name(s) _____

Title of Book _____

Question	✓
Is there a minimum of 5 pictures and/or photographs?	
Are there at least 15 numbered pages, but not more than 30?	
Is the information factual and is it presented in a logical order? (45 points)	
Does the story have appropriate grammar, spelling, and punctuation? (10 points)	
If the book is not about you, does it have footnotes or a bibliography? (10 points)	
Are the illustrations creative and original? (10 points)	
Do the pictures match the story? (15 points)	
Does the book look neat? (10 points)	
Does the book have a hard cover?	
Is the book no larger than 10" x 12" and no smaller than 5" x 8"?	
Are the title and the author's name on the outside cover of the book?	
Is there a title page inside the book?	
Was the book written during this school year?	
Are the story and illustrations my/our own work?	

Write-A-Book

Student Checklist: Picture Story Book

Student Name(s) _____

Title of Book _____

Question	✓
Is there an illustration on each page?	
Are there at least 10 numbered pages, but not more than 30?	
Is there a well-defined plot or theme? (15 points)	
Is there a clear order to the ideas? (10 points)	
Does the story have appropriate grammar, spelling, and punctuation? (10 points)	
Are the illustrations creative and original? (40 points)	
Do the pictures match the story? (15 points)	
Does the book look neat? (10 points)	
Does the book have a hard cover?	
Is the book no larger than 10" x 12" and no smaller than 5" x 8"?	
Are the title and the author's name on the outside cover of the book?	
Is there a title page inside the book?	
Was the book written during this school year?	
Were the story and illustrations my/our own work?	

Write-A-Book
Student Checklist: Poetry

Student Name(s) _____

Title of Book _____

Question	✓
Are there at least 10 numbered pages, but not more than 30?	
Are the poems original and creative? (60 points)	
Do the poems have figurative language? (20 points)	
Does the story have appropriate grammar, spelling, and punctuation? (10 points)	
Does the book have a neat appearance? (10 points)	
Does the book have a hard cover?	
Is the book no larger than 10" x 12" and no smaller than 5" x 8"?	
Are the title and the author's name on the outside cover of the book?	
Is there a title page inside the book?	
Was the book written during this school year?	
Were the story and illustrations my/our own work?	

There must be one poem on each of your 10 pages.

Sample Layouts

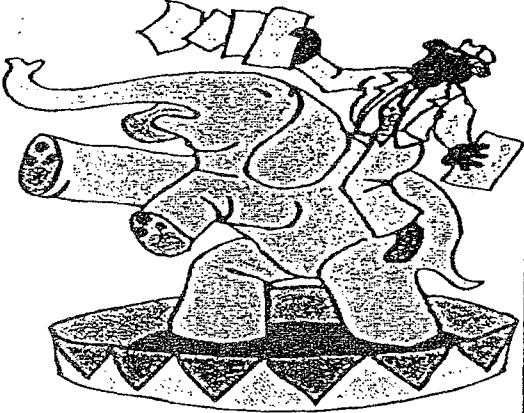
 A black and white illustration of a man riding an elephant. The elephant is standing on a circular platform with a scalloped edge. The man is sitting on the elephant's back, holding a large banner that says "CIRCUS".	<p>The man was on top of the elephant.</p> <hr/> <hr/> <hr/> <hr/>
--	--

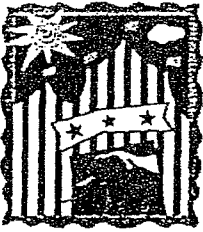
 A black and white illustration of a man riding an elephant. The man is sitting on the elephant's back, holding a banner that says "CIRCUS".	 A black and white illustration of an elephant in a circus tent. The tent has a striped pattern and a banner that says "CIRCUS".
<p>The Man is riding the elephant</p> <hr/> <hr/>	<p>The elephant is in the circus.</p> <hr/> <hr/>

Sample Layouts

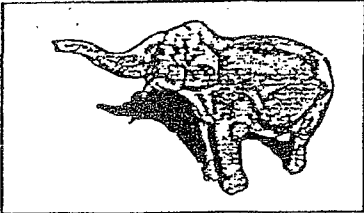

The elephant charged.

The elephant showered.



The elephant juggled the balls.



6. Attach the body of the book to the inside front cover with tape.

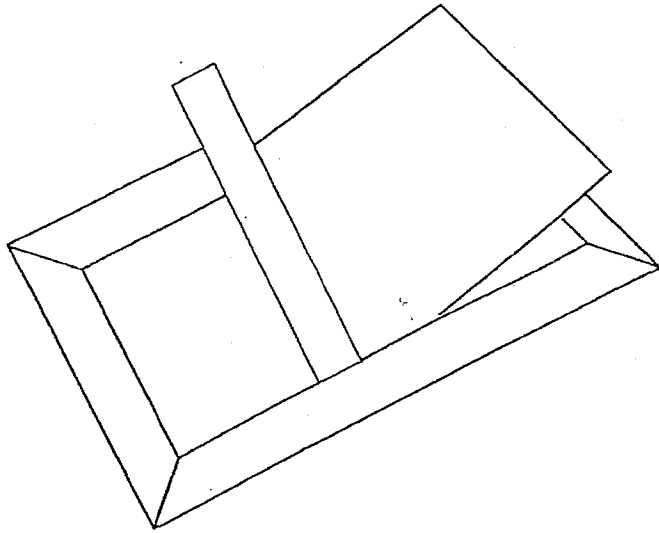

7. Secure the back cover to the body of the book in the same manner.
8. Cover the inside of the cardboard cover with construction paper. Your bookbinding is complete.

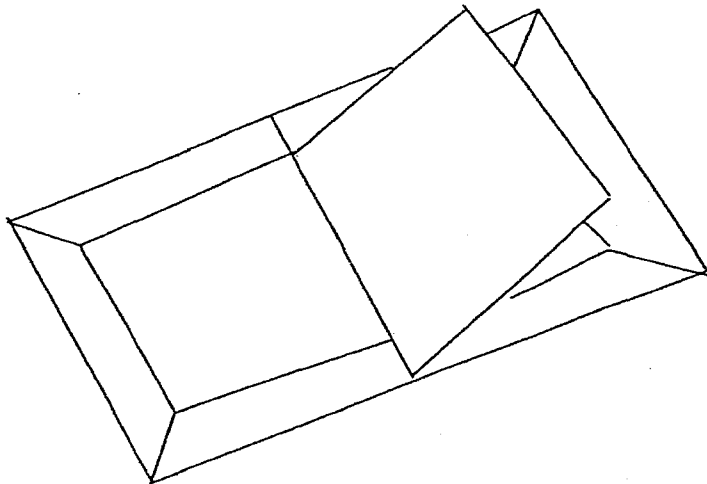

3. Cut the corners of the cover material.

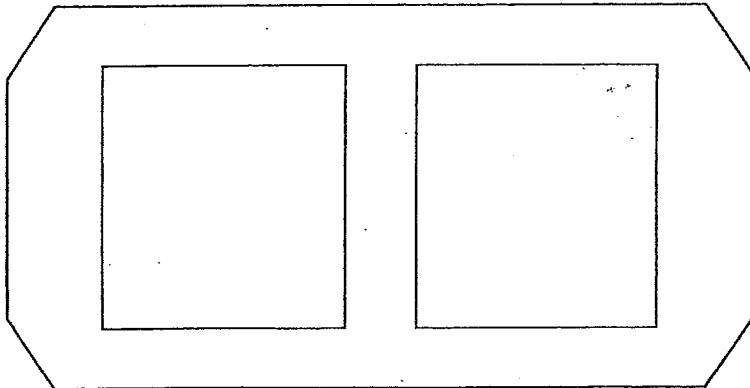

4. Fold the edges and glue them down.

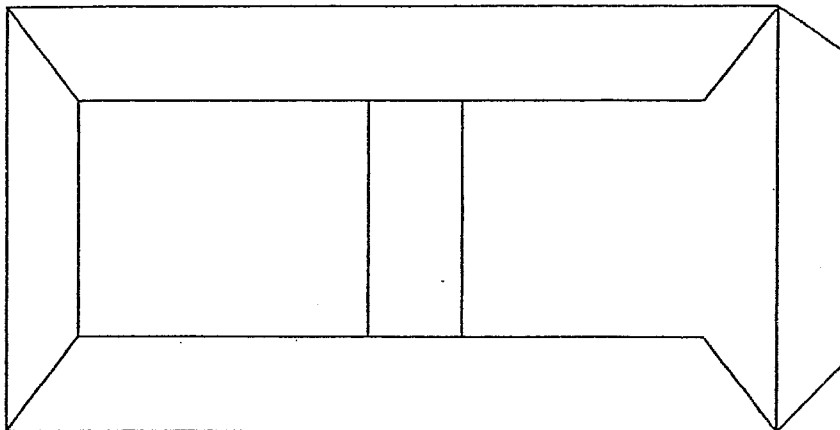

5. You now have a front and back cover attached.

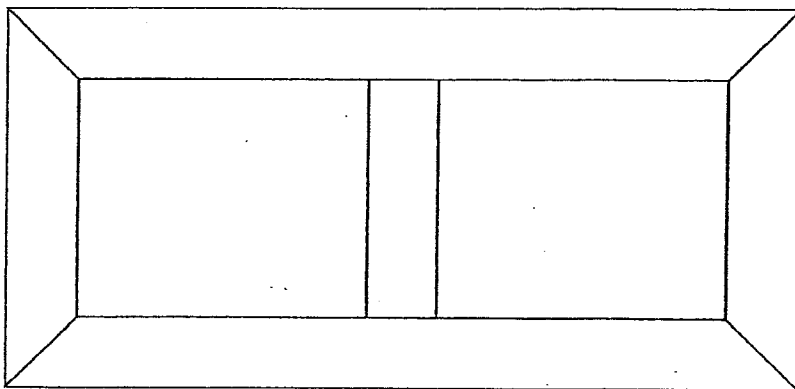

Book Binding Technique

Books may be side stitched, center stitched, side stapled or center stapled.

Materials Needed:

Stiff cardboard (from pasteboard box, foam board, etc.) Edges should be neat.

Material to cover it (construction paper, contact paper, wallpaper, fabric, etc.)

Glue, scissors, ruler

Note: The book should have a blank page at the beginning and end.

Procedure:

1. Cut two pieces of cardboard about $\frac{1}{2}$ " larger than page size.

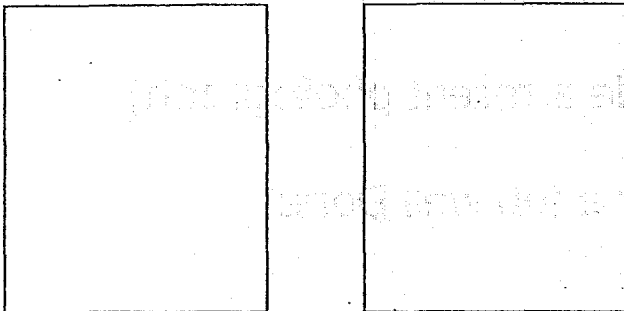

2. Cut one piece of cover material 1" larger than the 2 cardboards with space in the middle. The space in the middle should accommodate the thickness of the body of the book.

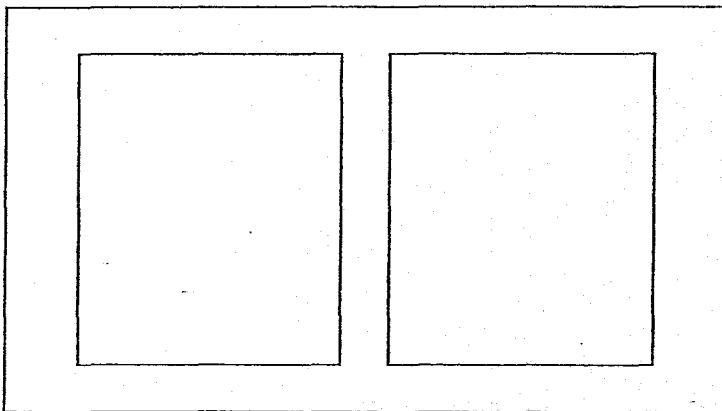

THE COMPLETED BOOK

Before you turn in your finished book make sure you have checked each item below

- Cover (title, author, picture)
- Extra sheet of paper in front and back (fly leaf pages)
- Title page (Title, author, school, date)
- Text (story with colorful pictures, except short story)
- Page numbers on Text section
- About the Author (include a recent photograph)
- Congratulate yourself for a job well Done